

FLOTTWEG NOZZLE SEPARATOR

Maximum separation and high solids yield
thanks to large clarification surface and efficient design



 **Flottweg**

Engineered For Your Success



CONTENTS

Uses and benefits	Page 02
Functional principle and design	Page 04
Features and specifications	Page 05
Innovation from practice	Page 07
Technical data	Page 09
Flottweg quality and service	Page 10



USES AND BENEFITS

Starch is our strength

Starch extraction is a prime example of the performance of Flottweg nozzle separators: It requires optimal clarification while still yielding a high solids content and high product quality, which is necessary for further processing of the starch. For example, as seen in the food industry, the paper and cardboard industry, or the chemical, pharmaceutical, and cosmetics industry.

Intelligent engineering, clever design, and long-lasting quality – Flottweg has the answer to your question:

- How can solids and liquids be separated as completely as possible while also saving energy?
- How can solids be fractionated again after separation?
- How can the largest possible solids content be extracted within a short period of time?
- How can separation processes be further optimized in terms of residual moisture, clarification, speed, and efficiency?



Flottweg provides nozzle separators with the largest possible clarification surface and the ability to process large quantities thanks to the continuous discharge of solids. As such, they can also be used in the following areas, for example:

- Biotechnology processes
- Treatment of mining wastewater
- Processing of thin stillage



INNOVATOR
des Jahres 2023



GERMAN
INNOVATION
AWARD '23
SPECIAL

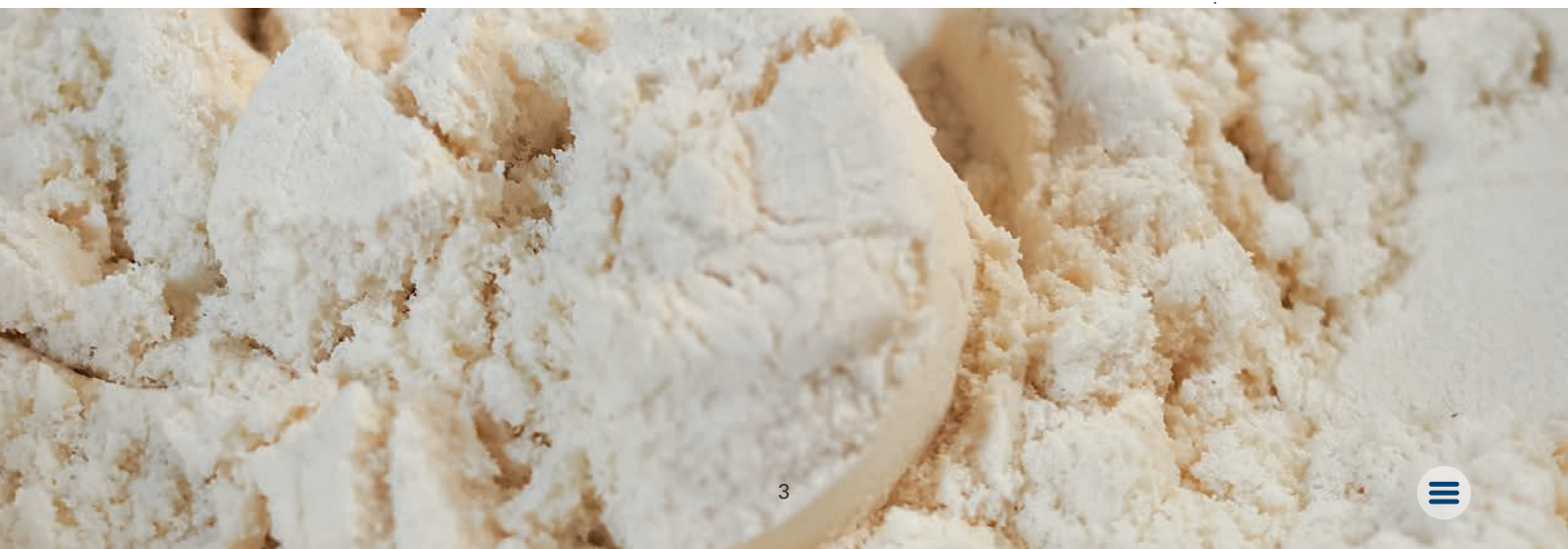

FUNCTIONAL PRINCIPLE AND DESIGN

01

All Flottweg nozzle separators are able to continuously separate solids from liquids. They guarantee the highest efficiency for clarification and separation. The product to be clarified or separated flows via a stationary inlet pipe into the inside of the bowl and is gently accelerated to operating speed by the distributor. Flottweg nozzle separators are available as 2-phase and 3-phase separators.

02

The 2-phase nozzle separator separates large solid particles directly in the centrifugal field. Finer solids are separated as they flow through the disc pack. The solid particles collect in the bowl's outer solids chambers. From there, they are continuously discharged via the nozzles. The clarified liquid flows from the disc pack and is discharged under pressure by an impeller.

03

With the 3-phase nozzle separator, larger solid particles are separated as they flow through the disc pack and are directed to the edge of the bowl due to the high centrifugal force. There, they collect in the bowl's outer solids chambers and are continuously discharged through the nozzles. The remaining product stream divides into a concentrate phase and fraction. Solids with a smaller particle size form the fraction, which is discharged under pressure. The remaining liquid flows through the disk pack. This results in a concentrate phase that is almost clear. This is also discharged under pressure by an additional impeller.

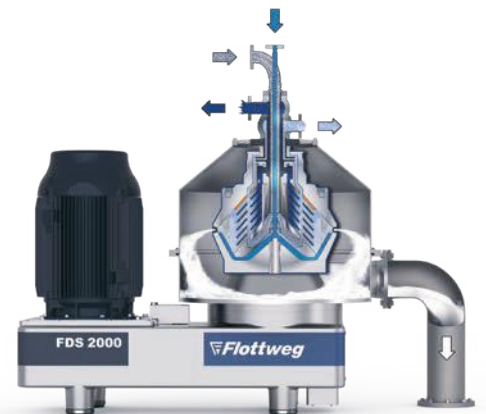
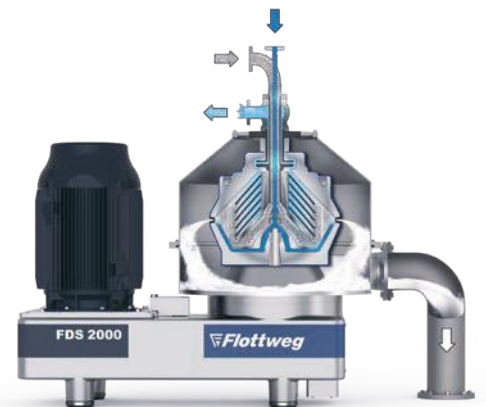



FEATURES AND SPECIFICATIONS



The Flottweg nozzle separator in 2-phase and 3-phase configuration

Our Flottweg nozzle separators are available in two basic designs: A 2-phase version for the separation of solids from liquids, and a 3-phase version for the separation of solids from liquids and the fractionation of different particle sizes. This makes Flottweg nozzle separators perfect for integration into existing applications and production processes.



The compact spindle drive

- Reduced starting current, quickly reaches working speed
- Flexible adaptation to product requirements thanks to simple, variable speed control
- Low vibration operation
- Reduced power consumption and low mechanical load
- Standard drive motors, meaning high availability
- Low-wear design for drive with contact-free seals
- Modular design for easy maintenance
- Quick replacement of compact spindle

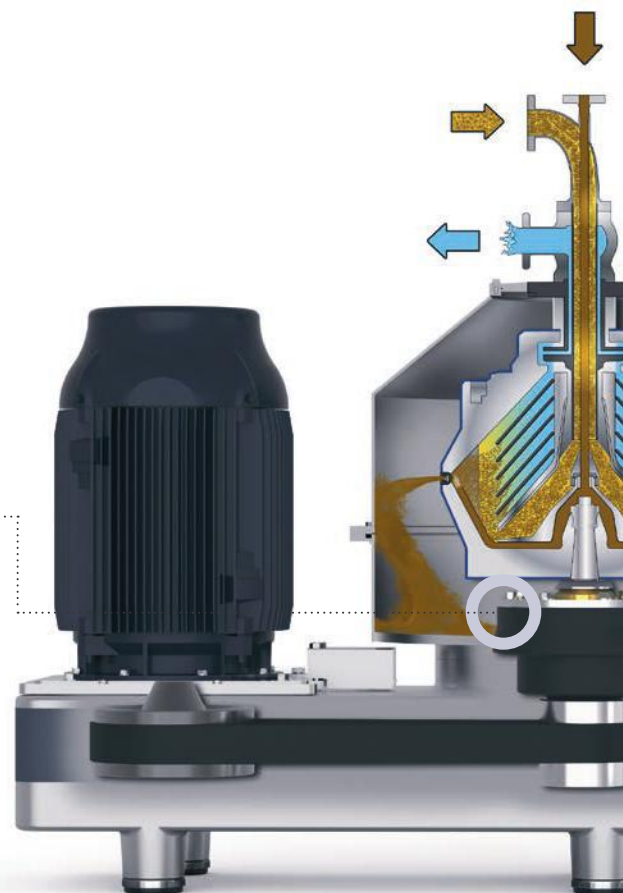

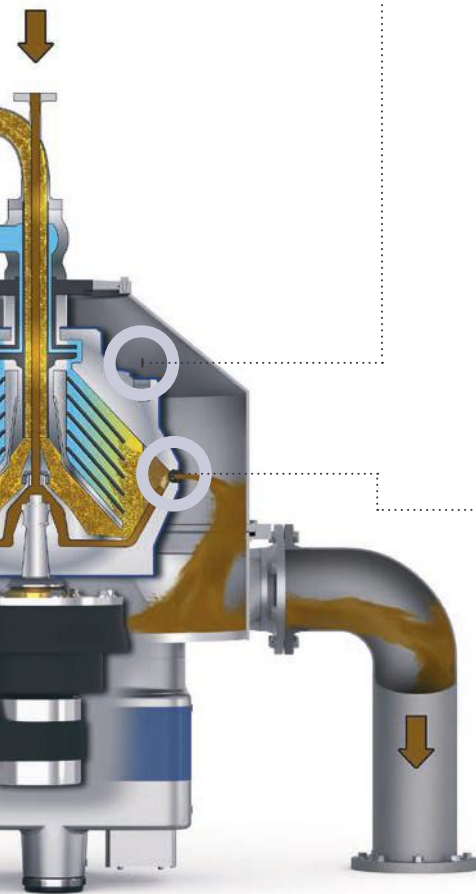

The bowl

- Innovative design of bowl interior that meets the highest hygiene requirements
- Smooth operation
- Optional: Solids washing device as contactless and maintenance-free pipe-in-pipe system
- Optional concentration for consistent balancing of product fluctuations in process
- Easy maintenance: The complete bowl is a compact assembly.

The nozzles

- The carbide nozzles can be changed quickly and easily, which means that the system can be adjusted to perfectly match the product being processed.
- Nozzles available in different diameters for optimal adaptation to the production process
- Carbide wear protection for a long nozzle service life
- Maximum energy recovery from solids discharge thanks to innovative positioning of nozzles

INNOVATION FROM PRACTICE

Developed with and for our customers

Flottweg nozzle separators are used to separate solids from liquids, thus making highly efficient clarification or separation possible. Our nozzle separator was developed for this, with our customers and for our customers.



Centrifugal acceleration

- The nozzle separator is able to generate g-forces of up to 9000g.
- Efficient clarification and separation is ensured by the high g-forces.

Master of saving

- Maximum energy savings thanks to innovative bowl design
- Optimized flow conditions within machine
- Consistent weight optimization for rotating components

Hygienically safe

- Developed according to principles of hygienic design
- Deposit-free solids discharge
- High-quality stainless steel used in components that come into contact with product
- Easy integration into CIP processes

Intelligently designed

- Closed lubrication circuit, meaning fewer wear parts
- Contactless seals
- Carbide wear protection for a long nozzle service life
- Belt drive for high machine availability
- Quick assembly and disassembly of compact spindle drive, meaning lower service and maintenance costs



TECHNICAL DATA

Technical data: Flottweg nozzle separator*

	FDS2000-210	FDS2000-231
Configuration	Concentrate phase via centripetal pump	Concentrate phase & fraction via centripetal pump
Bowl volume	60 l	60 l
Nozzles	12x	12x
G-force	max. 9000 x g	max. 9000 x g
Rotational speed	max. 5200 rpm	max. 5200 rpm
Motor power	75 - 110 kW	90 - 110 kW
Hydraulic power	160,000 l/h	160,000 l/h

* The figures given are only for reference. Effective throughput rates depend on the characteristics of the product. Subject to technical changes.

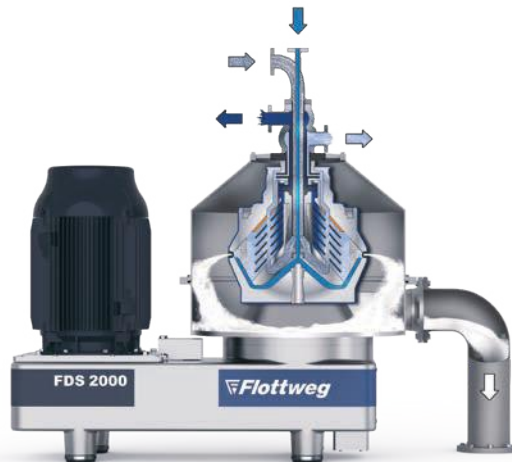
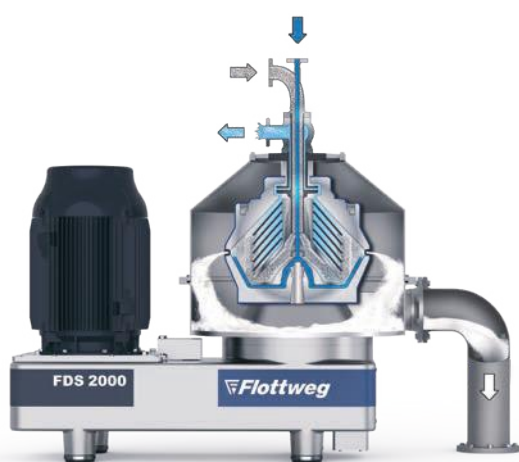

FLOTTWEG QUALITY AND SERVICE



Guaranteed Flottweg quality

Made in Germany We have a clear image of quality, and we never compromise on it. All components in Flottweg nozzle separators that come into direct contact with the product are made exclusively of high-quality stainless steels that are resistant to rust and acid. This means higher strength and improved resistance.

Our machines are well-equipped, and can withstand your requirements in the long term – in extreme cases, that can mean 24 hours a day, 7 days a week. Additionally, product safety is ensured by our strict quality controls (DIN EN ISO 9001:2015) and the traceability of all critical components.



Our service – we are always there for you!

We have over 1,100 employees worldwide, in a network of over 60 sales and service stations that are available to you. We are not only striving to provide first-class advice about selecting and designing our systems. We'll be there for you whenever you need us – 7 days a week in over 100 countries all over the world.



You can plan success. In just three steps.

Would you like to turn efficient separation or clarification into your own success story?
Then get in touch with Flottweg and benefit from our 3-step roadmap:

01

We will talk to you about protein separation and the business objectives you are looking to achieve.

02

During the pre-engineering phase, we subject your nozzle separator to individualized testing at the Flottweg Technical Center or on site at your business. Here, initial product samples can already be made available to you.

03

After the design and development phases, you receive a specific offer that includes all relevant line KPIs. As a result, you receive a nozzle separator that matches your process perfectly and acts as a stand-alone machine, and you receive a complete process that adds value.

**Make Flottweg the key player in your success:
Our sales partners are looking forward to hearing about your ideas and challenges!**



Flottweg worldwide

11
international
subsidiaries

Projects in over

100
countries

Over
50
service centers

- - Headquarters
- - Subsidiary
- - Representative



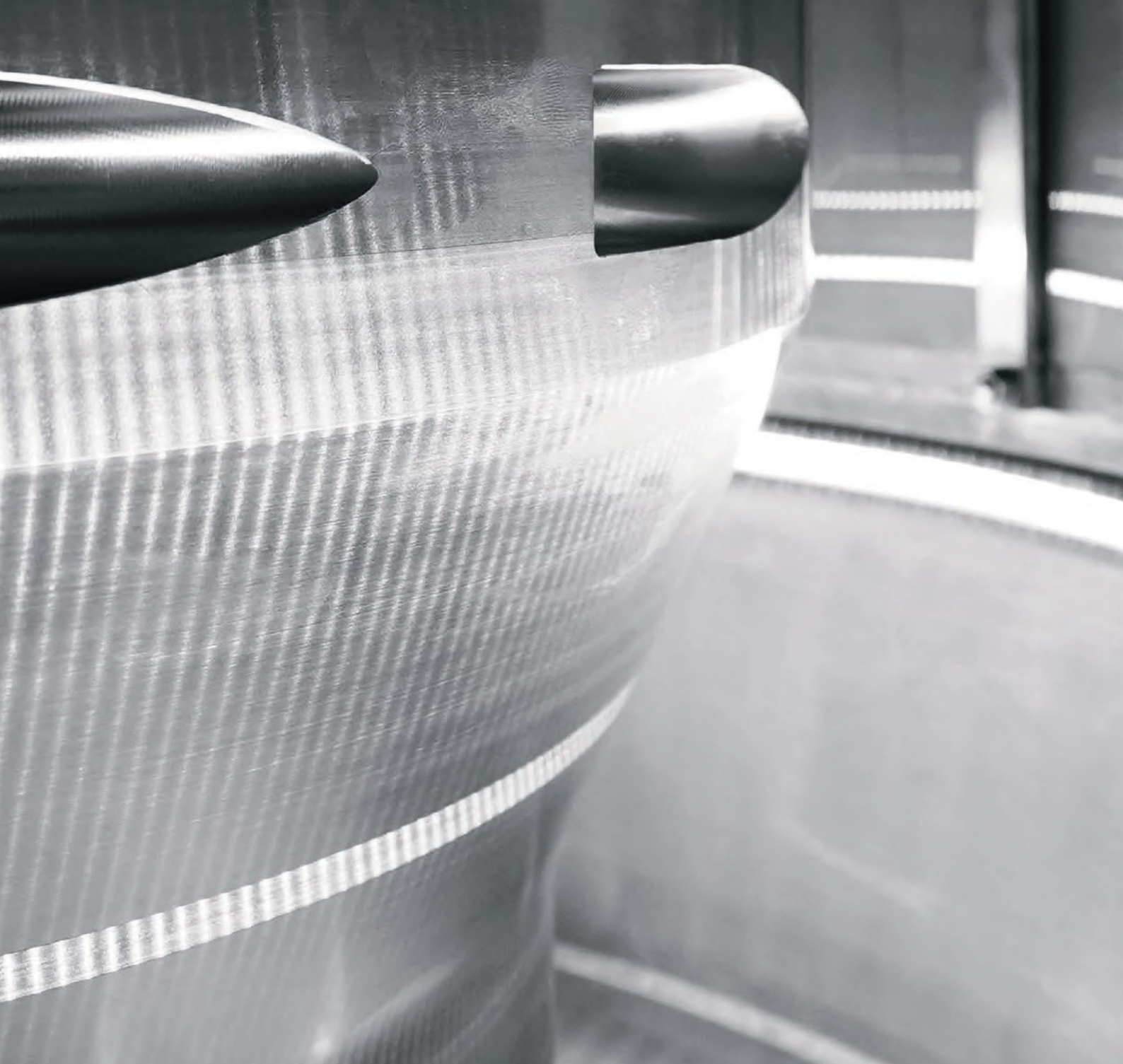

Flottweg SE

Industriestraße 6-8
84137 Vilsbiburg
Deutschland (Germany)
Tel.: + 49 8741 301-0
Fax: + 49 8741 301-300
[Contact form](#)
mail@flottweg.com
www.flottweg.com

