

A NEW GENERATION OF DISC STACK CENTRIFUGES

**SMALL DISC STACK CENTRIFUGE  
WITH HUGE POTENTIAL**

The New Flottweg High Performance  
Disc Stack Centrifuge AC 1200



# ROBUST – FLEXIBLE - EASY TO MAINTAIN

## The New Flottweg Disc Stack Centrifuge AC 1200

The clarification or separation of liquids plays a key role in many industrial processes. Flottweg has revised the complete product design of its disc stack centrifuges and optimized the machines for small and medium-sized companies.

The result is an intelligent centrifuge concept that sets itself apart with high clarification performance, outstanding product yield as well as user-friendly handling and flexibility. The machine has been developed specifically for the brewing and beverage industry. Moreover, there is a special product line for the olive oil industry. Thus, there are many applications in the production processes of small and medium-sized companies.

Flottweg has a worldwide reputation for reliability and quality. These principles are also integrated into the new AC 1200, not only regarding the design. An innovative solution, engineered for your success!

### The new AC 1200 at a glance

- Optimum product yield thanks to the accurate and silent Soft Shot® discharge system
- User-friendly handling and easy maintenance
- Individual process integration and parametrization in compliance with customer demands
- High flexibility and minimum footprint (skid base area approx. 2 square meters)



#### NEW BASIC DESIGN

- Easy access for maintenance work
- Compact design resulting in a small footprint
- Easy and flexible integration into existing processes



#### EFFICIENT BELT DRIVE

- Energy-efficient
- Low vibrations and low noise
- Standard drive motors, thus high availability
- Easy to maintain, low wear

#### TECHNICAL INFO

- 1 product feed
- 2 discharge of the clarified liquid under pressure
- 3 hydrohermetic (optional)
- 4 solids discharge

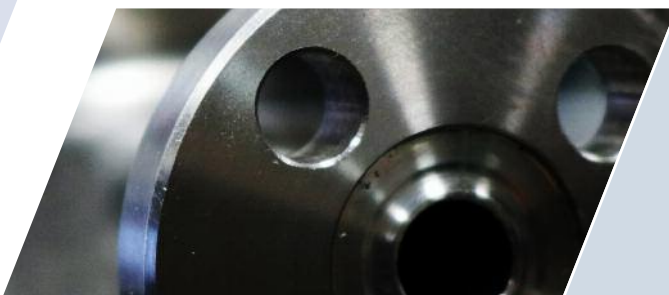



### OPTIMIZED BOWL OF THE DISC STACK CENTRIFUGE

- High clarification performance results in a higher productivity of the machine
- Easy to maintain thanks to the compact and sturdy design
- For the beverage and food industries:
- High surface quality of the product-wetted parts for safe production and efficient CIP
- Easy mounting and dismantling



### OPTIMIZED FLOTTWEG SOFT SHOT® SYSTEM

- Accurate partial and total discharges in any combination for maximum product yield
- Reduced discharge times for optimum separation results
- Material-friendly, silent, nearly inaudible solids discharge



### OPTIMIZED SPINDLE BEARING

- Efficient power transmission from the gear to the bowl
- Simplified basic construction results in minimum wear and reduced operating costs

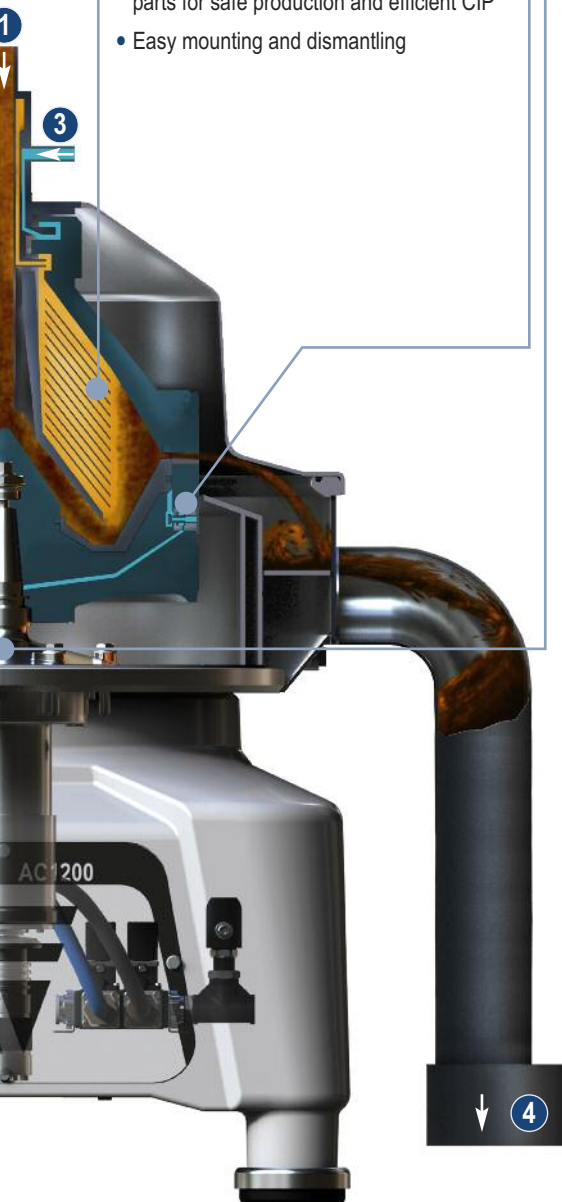

## Applications of the AC 1200

- Production of fruit juice; clarification, turbidity adjustment
- Wine production: must and wine clarification
- Brewing industry: green beer clarification, pre-clarification before filtration, turbidity adjustment
- Olive oil recovery: olive oil polishing
- Processing of animal by-products: Separation of solids and water



# Flottweg Separation Technology – Engineered For Your Success



Flottweg SE  
Industriestraße 6-8  
84137 Vilsbiburg  
Deutschland (Germany)

Tel.: +49 8741 301-0  
Fax: +49 8741 301-300

mail@flottweg.com  
www.flottweg.com

REPRESENTATIVE